

Metal Detection

MD-T2

GENERAL PURPOSE METAL DETECTOR

The MD-T2, when installed on a conveyor system, provides protection to downstream processing equipment by detecting the presence of potentially damaging metal objects. It is designed to detect all types of tramp metal, ferrous and non-ferrous.

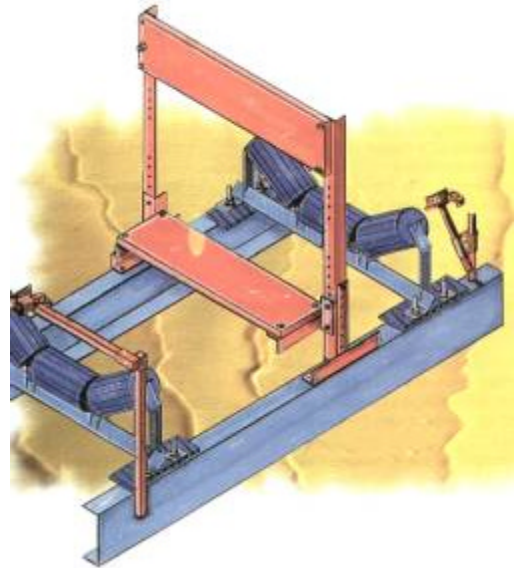

BENEFITS:

- Consistent alarm on predetermined size, no false tripping on small pieces.
- Easy servicing, low maintenance cost and interchangeable boards.
- Display status of the detection circuitry to aid in troubleshooting.
- Continues to identify additional metal after the alarm.
- Minimal downtime.

FEATURES:

- Prefabricated In Stock
- Detection Field Uniformity
- Single Solid State Plug-In Electronics
- Self Test Circuits
- Multiple Metal Identification
- Three Year Warrant with loaner¹

Note: ¹ Loaner includes standard electronic modules and is shipped at factory expense. Hassle free.

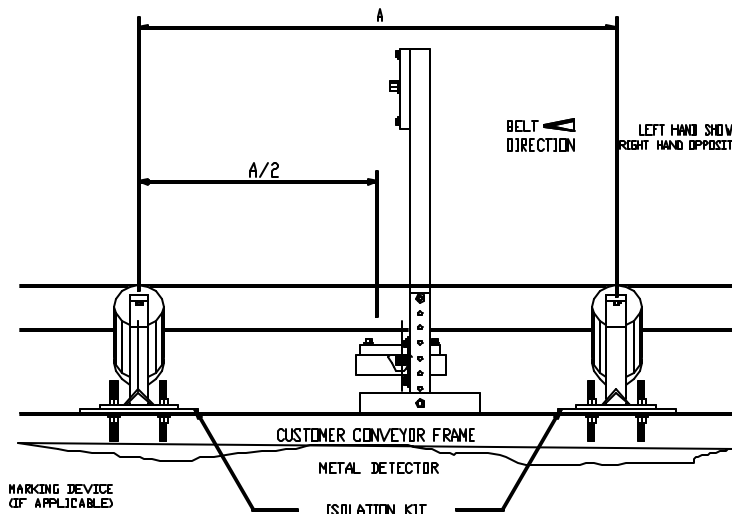
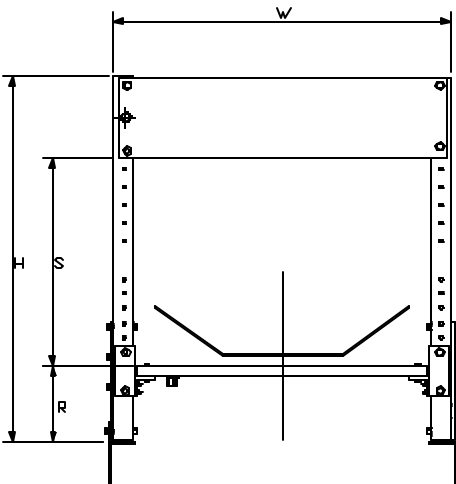

Letter	Dimensions
A	48.0
H	34.25
R	4.50 to 9.0
S	11.1 to 23.50
W	46.0

Specifications:

Power Requirements: 115 VAC (±10%)
Power Required: No Output Load 35 Watts
 Max Output Load 1185 Watts
Output Signals: Direct Output 115 V, 5A (Max)
 Timed Output 115 V, 5A (Max)
Sensitivity Drift: Less than 10%
Dust And Humidity: No Restrictions
Operating Temperature: -40° (-40°C) to +140°F (+60°C)



Arch Environmental Equipment, Inc
 Electrical Controls Division

5929 Benton Road
 Paducah, KY 42003

PH: (800) 553-4567

FAX: (800) 230-9462

Metal Detection

MD-T2 Metal Detection Chart

Overburden Height (in.)	Clearance	Aperture Height (in.)	CARBON STEEL	STAINLESS STEEL
0	4	4	0.4	0.50
1	4	5	0.5	0.63
2	4	6	0.6	0.75
3	4	7	0.7	0.88
4	4	8	0.8	1.00
5	4	9	0.9	1.13
6	4	10	1.0	1.25
7	4	11	1.1	1.38
8	4	12	1.2	1.50
9	4	13	1.3	1.63
10	4	14	1.4	1.75
11	4	15	1.5	1.88
12	4	16	1.6	2.00
13	4	17	1.7	2.13
14	4	18	1.8	2.25
15	4	19	1.9	2.38
16	4	20	2.0	2.50
17	4	21	2.1	2.63
18	4	22	2.2	2.75
19	4	23	2.3	2.88
20	4	24	2.4	3.00
21	4	25	2.5	3.13
22	4	26	2.6	3.35
23	4	27	2.7	3.38
24	4	28	2.8	3.50



Arch Environmental Equipment, Inc

Electrical Controls Division

5929 Benton Road
Paducah, KY 42003

PH: (800) 553-4567

FAX: (800) 230-9462