

Who is Arch Environmental?

*manufacturer and worldwide distributor of preferred bulk conveyor components since 1975

Mechanical Division

Belt Cleaners • Belt Alignment • Sealing Systems • Dust Control Systems • Impact/Slider Systems

Electrical Division

Belt Scales • Metal Detectors • Pull Cord Switches • Belt Protection Devices • Conveyor Control Systems

*facilities include a fabrication shop, a CNC machine shop, and state-of-the-art urethane production



Patented dual *Twister Tensioners* maintain consistent blade-to-belt pressure without re-tensioning and the cores are **GUARANTEED FOR LIFE!**

Heavy-duty frame with interlocking mainframe and support tubes with multiple set-screw locking collars.

Enormous curved, segmented blade is the toughest on the market and easily withstands multiple belt splices.

Shock-absorbing urethane bushings prevent pipe and frame damage.

Increases life of belts and idlers by eliminating harmful carryback.

Available for up to 96" belts.

SUPER SABER® PRIMARY CLEANER

ENORMOUS super-premium polyurethane blade segments make the *Super Saber*® the most rugged cleaner on the market.

- | | |
|-----------------|---|
| EZ Installation | ✓ |
| Low Maintenance | ✓ |
| Splice Safe | ✓ |
| Super-Duty | ✓ |
| Fast Delivery | ✓ |

Heavy-duty steel frame is the backbone of the *Super Saber*® and will not bend or buckle under ANY circumstances.

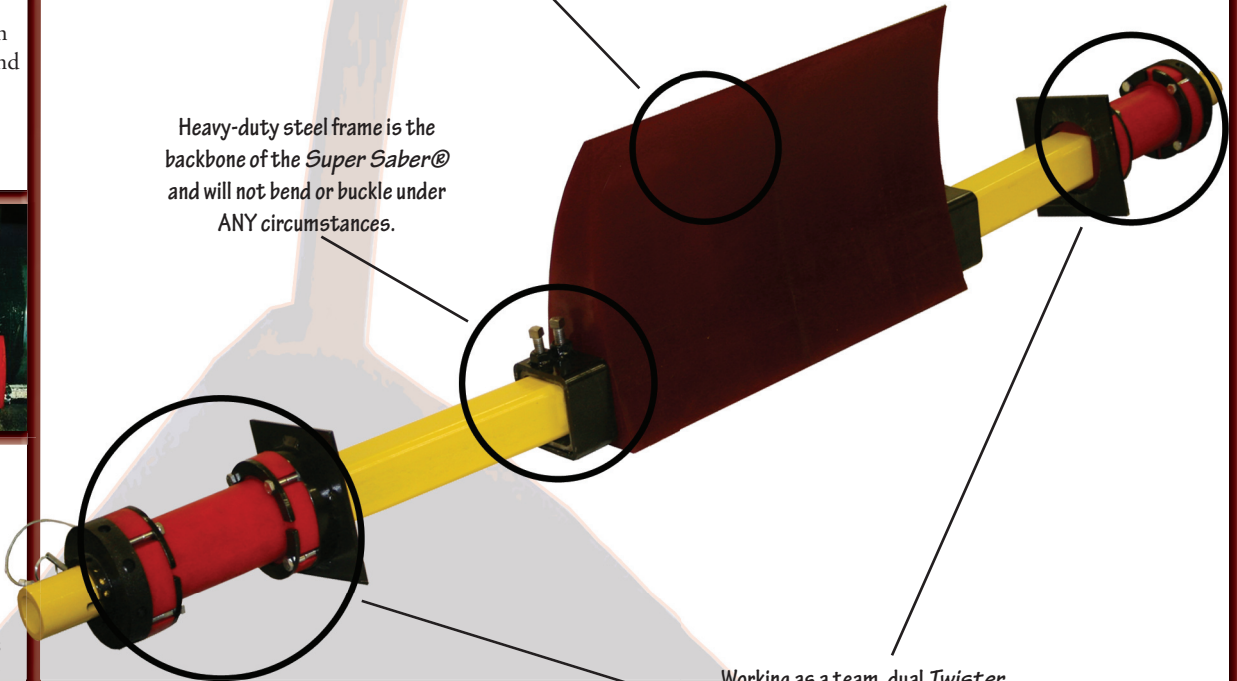

Working as a team, dual *Twister Tensioners*® hold this massive blade to the belt. NO MANUAL ADJUSTMENTS NEEDED!

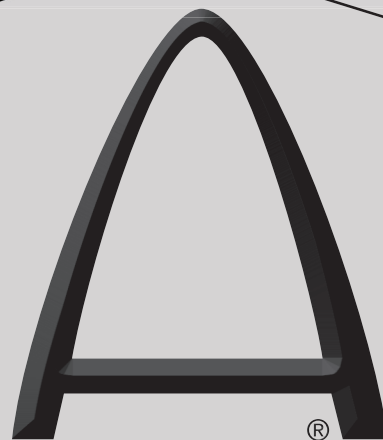

(Conveying Confidence from Tail to Head)

ARCH
ENVIRONMENTAL
EQUIPMENT, INC.

CONVEYOR EFFICIENCY SPECIALISTS

800-553-4567

www.archenv.com



SUPER SABER® PRIMARY CLEANER

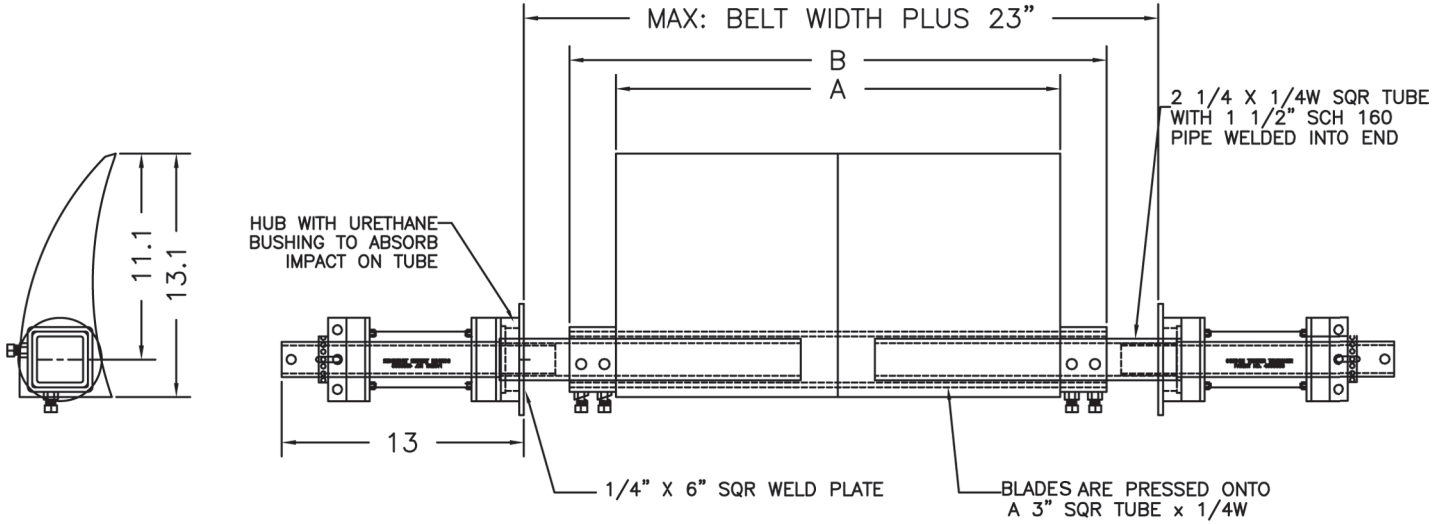

BELT WIDTH	SUPER SABER BELT CLEANER ALL DIMENSIONS IN INCHES		
	A	B	ORDER #
18	17.48	22.48	MCNXS000180000180DT000000000000
24	23.31	28.32	MCNXS000240000240DT000000000000
30	29.18	34.18	MCNXS000300000300DT000000000000
36	34.96	39.96	MCNXS000360000360DT000000000000
42	40.79	45.79	MCNXS000420000420DT000000000000
48	46.62	51.62	MCNXS000480000480DT000000000000
54	52.45	57.45	MCNXS000540000540DT000000000000
60	58.28	63.28	MCNXS000600000600DT000000000000
66	64.10	69.10	MCNXS000660000660DT000000000000
72	69.93	74.93	MCNXS000720000720DT000000000000
84	81.59	86.59	MCNXS000840000840DT000000000000
96	93.25	98.25	MCNXS000960000960DT000000000000

THE FOLLOWING OPTIONS ARE AVAILABLE:
ENTER THE SELECTED OPTION IN PLACE OF *

SS : STAINLESS PIPES

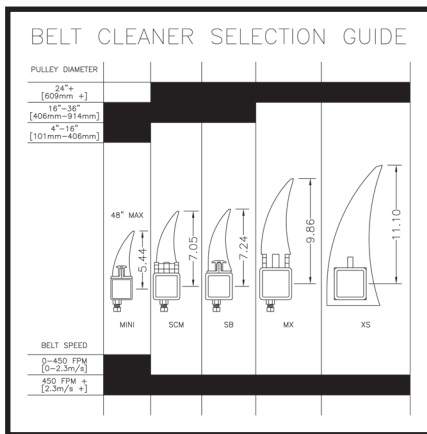

Standard Blade
Red
Temp. Range: 180-220°F

Non-pigment Blade
White
Same as Standard Red Blade
Ideal for color-sensitive material (ie. Borax, Soap, etc.)

Food Grade Blade
Natural
FDA approved for mild contact with food products



Covered under one or more of the following patents:
4,202,437; 4,231,471; 4,436,446; 4,489,823; 4,533,036; 4,779,716; 4,877,125;
4,989,727; 5,149,305; 5,222,588; 5,222,589; 5,219,063; 5,350,053; 5,725,083;
other patents pending

Note: If available, prices vary with options.